



FITTING INSTRUCTIONS FOR EH0080BK EXHAUST HANGER
KTM RC125, RC200 & RC390 '17-



THIS KIT CONTAINS THE ITEMS PICTURED AND LABELLED BELOW.
DO NOT PROCEED UNTIL YOU ARE SURE ALL PARTS ARE PRESENT.

Please note that the way the kit is packed does not necessarily represent the way of mounting to the bike.

THE PARTS SHOWN MAY BE REPRESENTATIVE ONLY (FOR CLARITY OF INSTRUCTIONS ONLY)

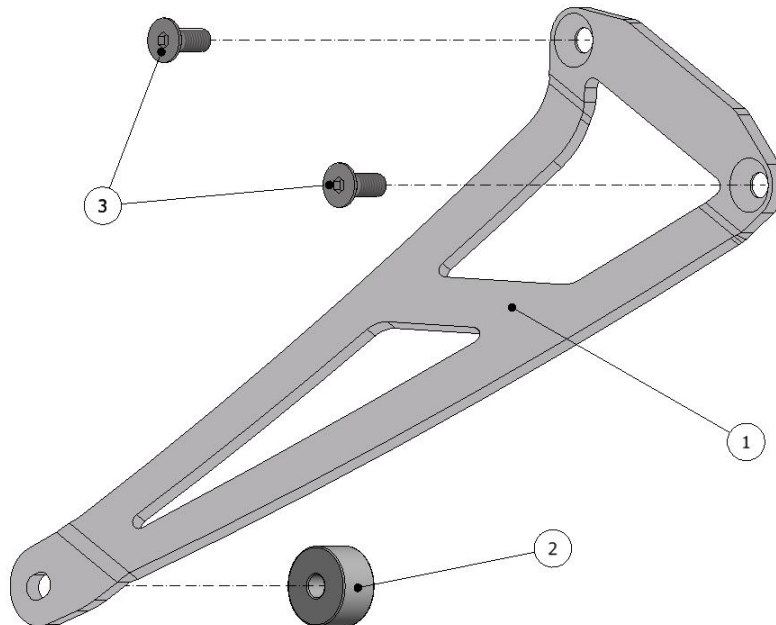

R&G Racing
Unit 1, Shelley's Lane, East Worldham, Alton, Hampshire, GU34 3AQ
Tel: +44 (0)1420 89007 Fax: +44 (0)1420 87301 www.rg-racing.com Email: info@rg-racing.com



LEGEND

ITEM 1 = EXHAUST HANGER (HB0080) (x1).

ITEM 2 = SPACER (S1043) (x1).

ITEM 3 = M8 x 20mm LONG COUNTERSUNK BOLT (x2).

TOOLS REQUIRED

- Set of metric Allen keys to include 6mm A/F sizes.

Please note that in cases where kits are packed with rubber washers holding the components onto the bolt – *the rubber washers should be thrown away!*

FITTING INSTRUCTIONS

- To fit the R&G Exhaust Hanger, the OEM pillion footrest mounting bracket needs to be removed.
- To do this, remove the two mounting bolts at the top of the pillion footrest mounting bracket.
- Remove the exhaust mounting nut and bolt and then remove the OEM pillion footrest mount from the bike.
- Take the R&G Exhaust Hanger and fit the two M8 x 20mm long countersunk bolts (item 3) through the two top mounts of the exhaust hanger and tighten into the threaded bosses on the subframe.
- With the exhaust hanger on the bike, ensure the lower part of the exhaust hanger is on the inside of the exhaust mounting bracket, position the spacer (item 2) on the back side of the exhaust hanger, so it sits between this and the rear of the exhaust mounting clamp, and re-fit the original bolt and nut.
- Ensure the exhaust hanger is correctly fitted before tightening all three bolts.
- Please ensure when the motorcycle is being used that no parts are in such a position that they may collide/damage other bike parts (this is particularly important if using after-market cans or exhaust systems).

Please note that it is your responsibility to ensure that no part of the exhaust hanger or exhaust assembly fouls or comes into contact with other parts of the machine. Do not ride the motorcycle until this aspect has been verified and you have compressed the rear suspension (if appropriate to the design of the motorcycle) to test this thoroughly.

ISSUE 1 30/06/2017 (AR)

CONSUMER NOTICE

The catalogue description and any exhibition of samples are only broad indications of the Products and R&G may make design changes which do not diminish their performance or visual appeal and supplying them in such state shall conform to the order. The Buyer acknowledges no representation or warranty (other than as to title) has been given or will apply to the Products other than those in R&G's order or confirmation and the Buyer confirms it has chosen the Products as being of merchantable quality and suitable for its particular purposes. Where R&G fits the Products or undertakes other services it shall exercise reasonable skill and care and rectify any fault free of charge unless the workmanship has been disturbed. The Buyer is responsible for ensuring that the warranty on the motorcycle is not affected by the fitting of the Products. On return of any defective Products R&G shall at its option either supply a replacement or refund the purchase money but shall not be liable if the Products have been modified or used or maintained otherwise than in accordance with R&G's or manufacturer's instructions and good engineering practice or if the defect arises from accident or neglect. Other than identified above and subject to R&G not limiting its liability for causing death and personal injury, it shall not be liable for indirect or consequential loss and otherwise its liability shall be limited to the amounts paid by the Buyer for the Products or the fitting or service concerned. These terms do not affect the Buyer's statutory rights.

R&G RACING RETURNS POLICY (NON-FAULTY GOODS)

Returns must be pre-authorized (if not pre-authorized the return will be rejected). Goods may only be returned direct to us if they were purchased direct from us (customer must prove if necessary). Otherwise to be returned to original vendor. Goods must be in re-sellable condition, in the opinion of R&G Racing. All returns are subject to a 25% restocking and handling fee (25% of the gross value exc. P&P – at the prevailing price at time of purchase). The customer must pay any and all carriage charges. No returns of discontinued products, unless within 14 days of purchase. This policy does not affect your statutory rights and does not refer to faulty goods.

R&G Racing

Unit 1, Shelley's Lane, East Worldham, Alton, Hampshire, GU34 3AQ

Tel: +44 (0)1420 89007 Fax: +44 (0)1420 87301 www.rg-racing.com Email: info@rg-racing.com



NOTICE DE MONTAGE POUR EH0080BK SUPPORT POT D'ÉCHAPPEMENT
KTM RC125, RC200 & RC390 '17-



Le kit contient les articles exposés ci-dessous, vérifier que toutes les pièces soient présentes avant de procéder au montage.

La façon dont le kit est emballé ne correspond pas forcément à la façon de monter les pièces sur la moto.

LES PARTIES PRESENTÉES PEUVENT ÊTRE UNIQUEMENT REPRESENTATIVES (POUR LA CLARTE DES INSTRUCTIONS UNIQUEMENT)

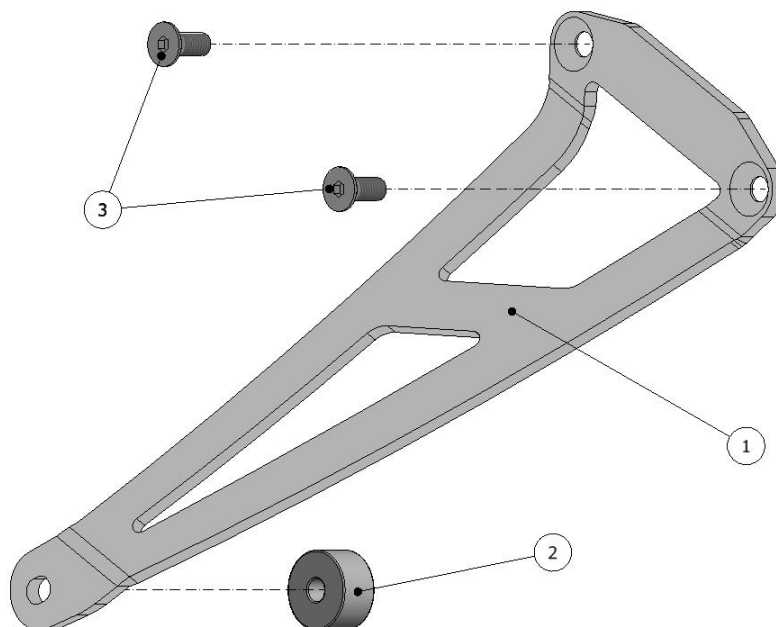

Unit 1, Shelley's Lane, East Worldham, Alton, Hampshire, GU34 3AQ
Tel: +44 (0)1420 89007 Fax: +44 (0)1420 87301 www.rg-racing.com Email: info@rg-racing.com



LEGENDE

ARTICLE 1 = SUPPORT POT D'ÉCHAPPEMENT (HB0080) (x1).

ARTICLE 2 = ENTRETOISE (S1043) (x1).

ARTICLE 3 = M8 x 20mm BOULON (x2).

OUTILS REQUIS

- Clés Allen 6mm.

Notez que si les kits sont emballés avec des rondelles en caoutchouc servant à tenir les composants, *ces rondelles doivent être jetées !*

NOTICE DE MONTAGE

- Pour monter le support R&G, le support de fixation de repose pieds passage d'origine doit être enlevé.
- Pour cela, enlever les 2 boulons de fixation sur le haut du support de fixation de repose pieds passager.
- Enlever l'écrou de fixation d'échappement et le boulon puis enlever le repose pieds passager d'origine de la moto.
- Prendre le support d'échappement R&G puis insérer les 2 boulons M8 x 20mm (article 3) dans les 2 supports supérieurs du support d'échappement puis serrer dans les patrons filetés du sous-cadre.
- Une fois le support d'échappement sur la moto, assurez-vous que la partie inférieure du support d'échappement soit à l'intérieur du support de fixation d'échappement, positionnez l'entretoise (article 2) au bas du support d'échappement, de façon à ce qu'il se place entre celui-ci et l'arrière de la pince de fixation d'échappement puis réinsérer le boulon et l'écrou.
- Veiller à ce que le support d'échappement soit correctement monté avant de serrer les 3 boulons.
- Vérifier qu'aucune partie de la moto ne puisse potentiellement heurter une autre partie de la moto lors de son utilisation (cela est particulièrement important si vous utilisez un pot d'échappement qui n'est pas d'origine).
- ***Il est de votre responsabilité de veiller à ce qu'aucune partie du support de pot d'échappement ne puisse entrer en contact avec d'autres parties de la moto. Ne pas utiliser la moto tant que ce point n'a pas été vérifié, en ayant compresser l'amortisseur arrière (si le design de la moto le permet).***

ISSUE 1 30/06/2017 (AR)

CONSUMER NOTICE

The catalogue description and any exhibition of samples are only broad indications of the Products and R&G may make design changes which do not diminish their performance or visual appeal and supplying them in such state shall conform to the order. The Buyer acknowledges no representation or warranty (other than as to title) has been given or will apply to the Products other than those in R&G's order or confirmation and the Buyer confirms it has chosen the Products as being of merchantable quality and suitable for its particular purposes. Where R&G fits the Products or undertakes other services it shall exercise reasonable skill and care and rectify any fault free of charge unless the workmanship has been disturbed. The Buyer is responsible for ensuring that the warranty on the motorcycle is not affected by the fitting of the Products. On return of any defective Products R&G shall at its option either supply a replacement or refund the purchase money but shall not be liable if the Products have been modified or used or maintained otherwise than in accordance with R&G's or manufacturer's instructions and good engineering practice or if the defect arises from accident or neglect. Other than identified above and subject to R&G not limiting its liability for causing death and personal injury, it shall not be liable for indirect or consequential loss and otherwise its liability shall be limited to the amounts paid by the Buyer for the Products or the fitting or service concerned. These terms do not affect the Buyer's statutory rights.

R&G RACING RETURNS POLICY (NON-FAULTY GOODS)

Returns must be pre-authorized (if not pre-authorized the return will be rejected). Goods may only be returned direct to us if they were purchased direct from us (customer must prove if necessary). Otherwise to be returned to original vendor. Goods must be in re-sellable condition, in the opinion of R&G Racing. All returns are subject to a 25% restocking and handling fee (25% of the gross value exc. P&P – at the prevailing price at time of purchase). The customer must pay any and all carriage charges. No returns of discontinued products, unless within 14 days of purchase. This policy does not affect your statutory rights and does not refer to faulty goods.

R&G Racing

Unit 1, Shelley's Lane, East Worldham, Alton, Hampshire, GU34 3AQ

Tel: +44 (0)1420 89007 Fax: +44 (0)1420 87301 www.rg-racing.com Email: info@rg-racing.com